

DK: Samvejledning og sikkerheds anbefalinger
UK: Assembly instruction and safety regulations

Cykelholder/Bike carrier

AMBER IV DELUXE

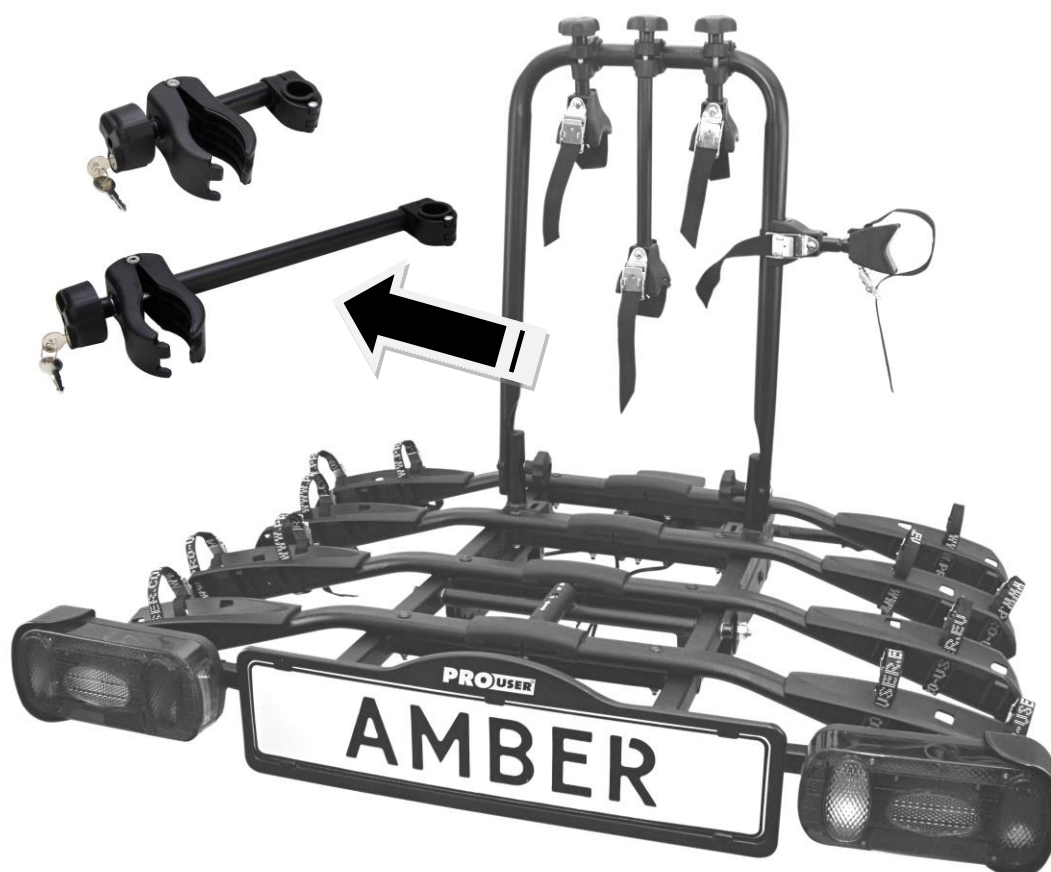

Max. kugletryk Max. ball pressure	Wægt cykelholder Weight bike carrier	Max. last Max. load
50kg	19,5kg	30,5kg
60kg	19,5kg	40,5kg
75kg	19,5kg	55,5kg
90kg	19,5kg	Max. 60kg

PROUSER BIKE CARRIERS®

European permission
E4-26R-03 0281

INTRODUCTION

Pro-User AMBER IV cykelholder producers af Tradekar Benelux BV, Holland

- ✓ Cykelholder til anhængertræksmontering
- ✓ Passer til alle typer DIN-anhængertræk
- ✓ Sikker og stabil, nem vippefunktion. Til transport af 4 cykler
- ✓ Nem montering på bilens anhængertræk uden brug af løst værktøj
- ✓ Vippefunktionen, gør det muligt at komme til bilens bagagerum selv med cyklerne monteret
- ✓ Cyklerne holdes i brede og stabile hjulholdere
- ✓ Samt cykelstelgribere med blødt gummi-indlæg.
- ✓ Fleksible arme passer til de fleste cykelstel
- ✓ Elsæt med både 7-pol og 13-pol stik (Jaegers)
- ✓ Inkl. Tågelygte og baklygte (virker kun med 13-pol stik)
- ✓ Cykelholderen kan aflåses til bilens anhængertræk
- ✓ Europa godkendelse givet af RDW

VIGTIG INFORMATION

Læs instruksvejledningen grundigt igennem inden ibrugtagning.

Samling og montering af cykelholder må kun ske ud fra denne vejledning. En fejlagtig samling og montering kan være katastrofal.

Cykelholderen er godkendt til transport af 4 cykler. Venligst tjek den maksimale lastevne i tabellen nedenfor. Tjek også hvor stort et kugletryk bilens anhængertræk er godkendt til. Se typeplade på anhængertrækket eller i bilens instruktionsbog.

Den maksimale lastevne for cykelholderen er **60kg** forudsat at bilen må laste 75kg på trækket. Cykelholderens vægt er **19,5kg**.

Max. kugletryk	Vægt cykelholder	Max. last
50kg	19,5kg	30,5kg
60kg	19,5kg	40,5kg
75kg	19,5kg	55,5kg
90kg	19,5kg	Max. 60kg

Kan ikke anbefales til anhængertræk I aluminiumsudførsel.

Gem denne instruktionsvejledning i bilen.

SAMLING AF CYKELHOLDEREN

Cykelholderen kommer usamlet. Tag alle dele ud af emballagen og arranger dem på gulvet som vist nedenfor.

Step 1

Dele:



Montering:

Placer de 8 hjulholdere på bundrammen. Fastgør dem med de 16 bolte M6x50, M6 planskiver og M6 møtrikker i bundrammen.

Saml de 2 lygter ved at sætte dem sammen og fastgør dem med den medleverede skrue M5x12 og planskiver.

Monter den nu samlede lygtebom på bundrammen ved hjælp af de 2 M5x35 bolte og planskiver.

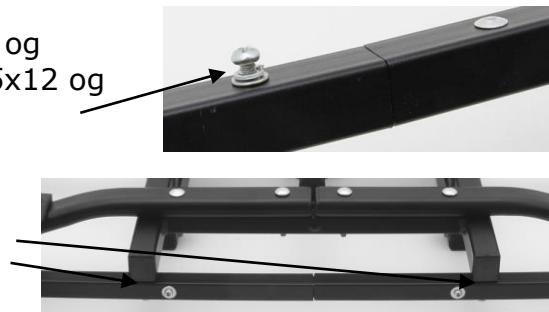

Vær opmærksom på at tågelygten er i venstre side af cykelholderen!

Resultat:

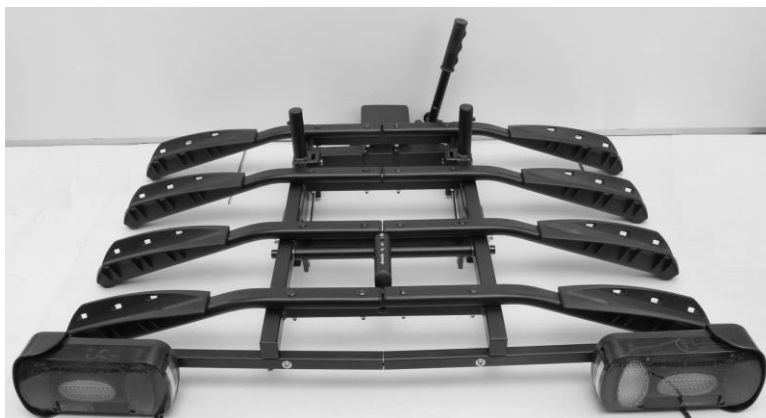

Step 2

Dele



Montering:



Monter den store U-bøjle på bundrammen. Benyt de medfølgende bolte (M8x60), planskiver og de store plast fingermøtrikker. Vær opmærksom på at de 2 store fingermøtrikker sidder på indvendig side (se foto).

Bemærk: Stram godt til, så u-bøjlen sidder urokkelig fast. U-bøjlen kan nedfældes fx ved opbevaring.

Resultat:



Step 3

Dele:

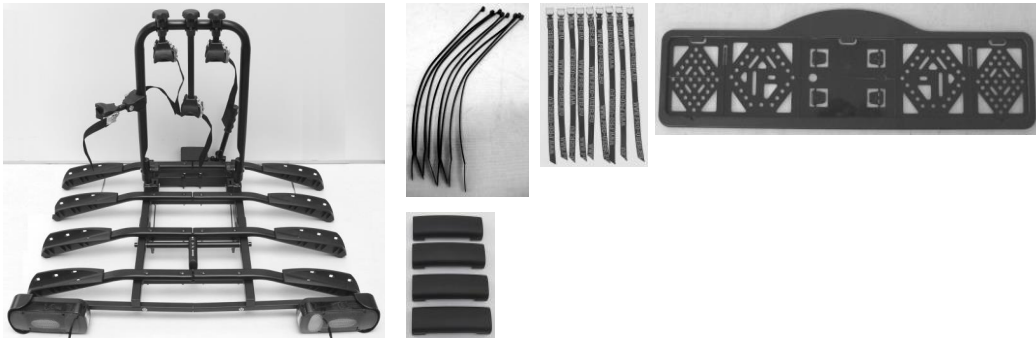

Montering:

Løsne de små skruer hvor nummerpladerammen skal side. Monter denne derpå på rammen. Nummerpladerammen skal være i samme højde som lygterne.

De medfølgende strips bruges til at føre og samle ledningerne. Trækkes frem til venstre side af cykelholderen, idet bilens stikdåse sidder til venstre for trækket. Vær opmærksom på at de ikke generer tiltfunktionen.

Før de 12 tekstilremme igennem hjulholderne og spænd dem. Husk altid at spænde dem, også selvom cykler ikke er på holderen, så du ikke risikere at miste dem under kørsel. (Se foto)



Sluttelig monteres de 4 plastik beskyttere midt imellem hjulholderne på rammen.

Slut resultat:



STELHOLDERNE

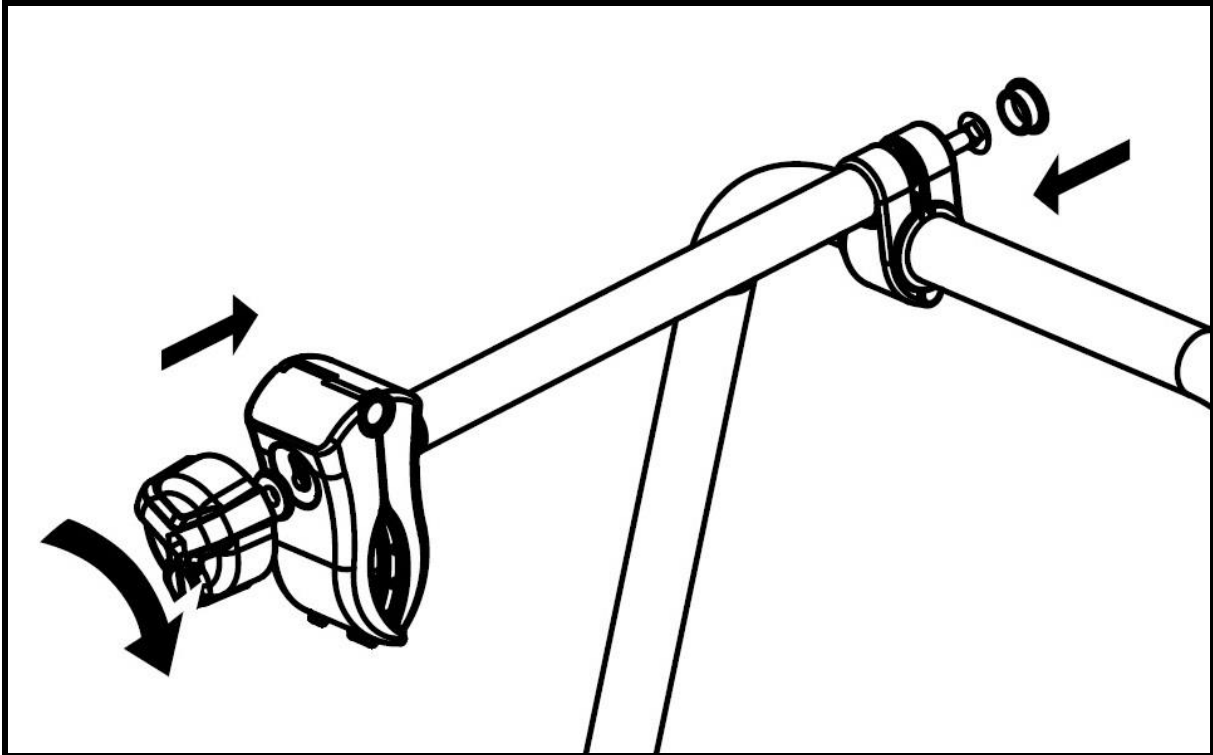
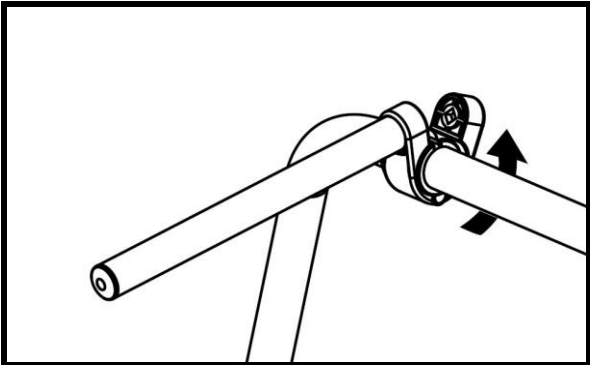
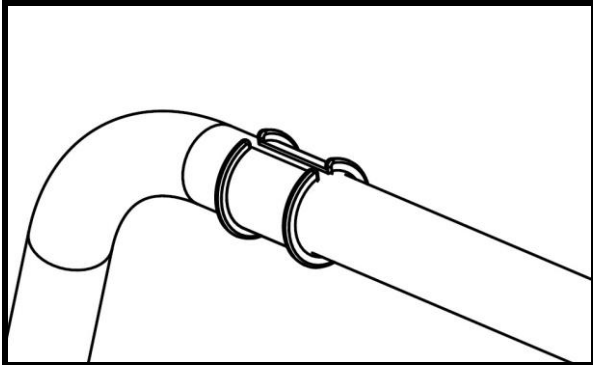
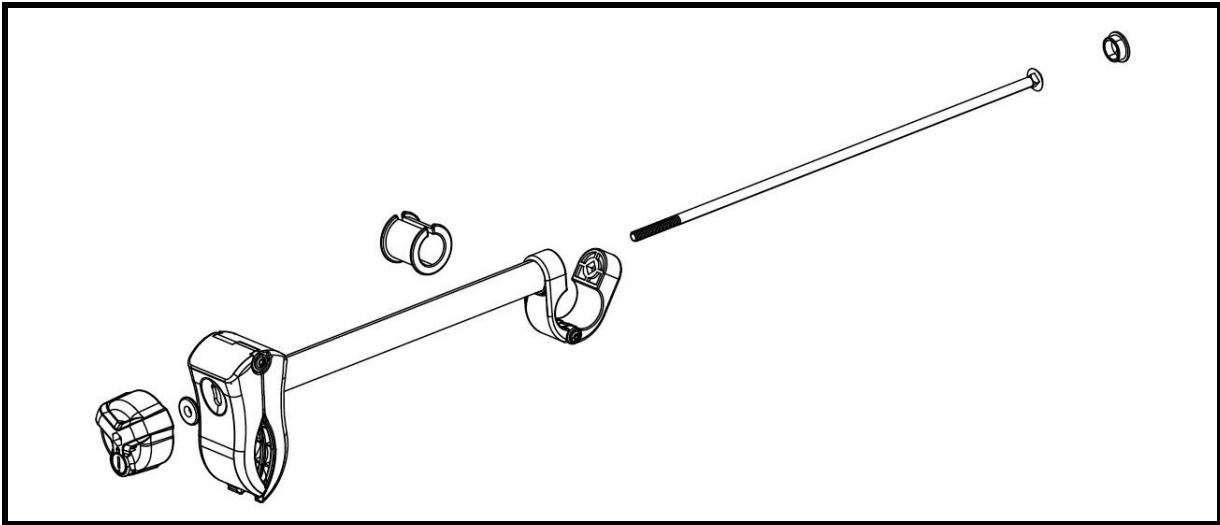

MONTERING AF CYKELHOLDER PÅ ANHÆNGERTRÆK

Vi anbefaler at du bliver fortrolig med brugen heraf.

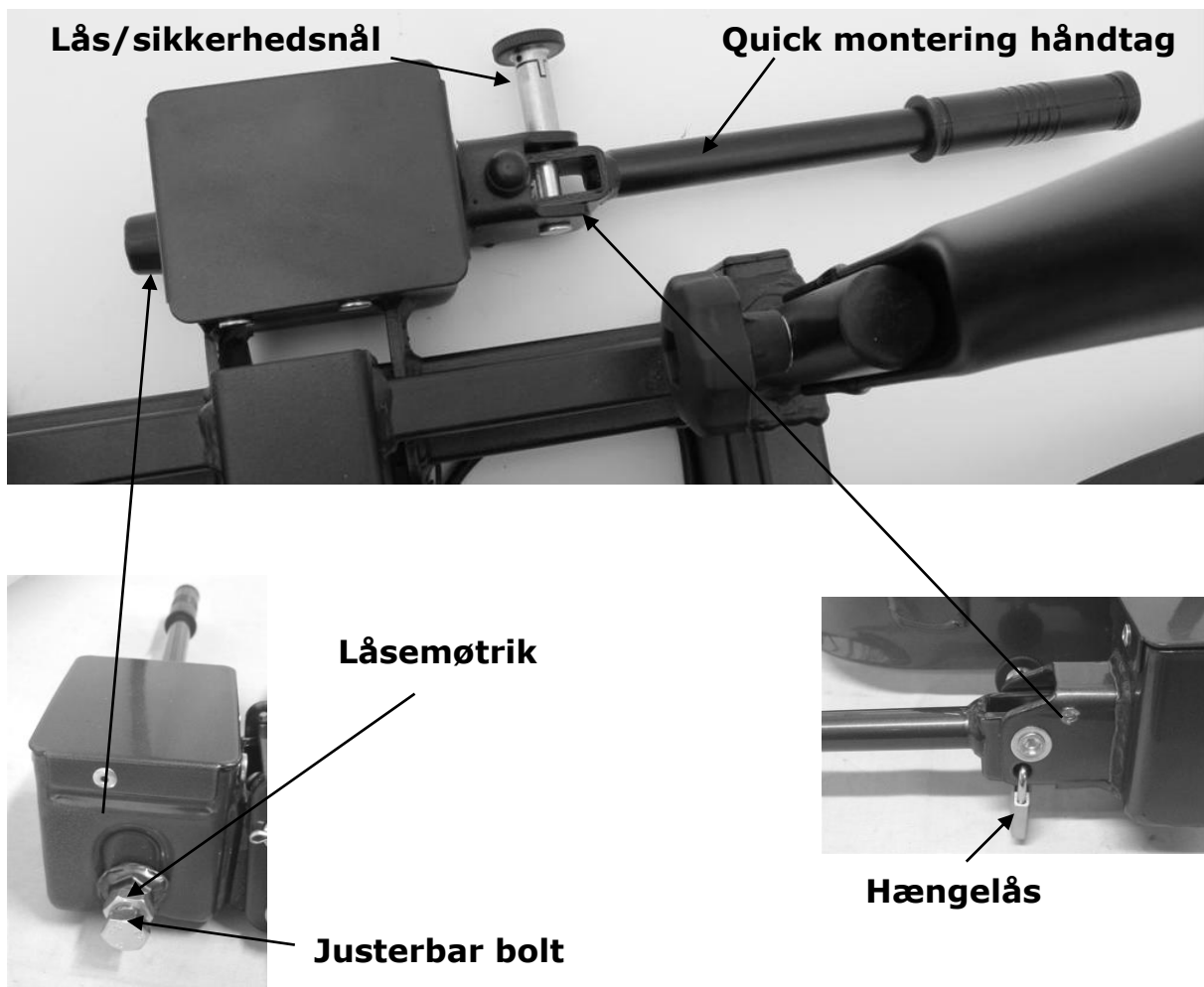

Quick monterings håndtag er formonteret på cykelholderen. Ved brug af denne fastgøres nemt og hurtigt cykelholderen. Cykelholderen er solidt fastmonteret, når håndtag står vandret og sidder urokkelig fra side til side og op og ned.

Når du monterer cykelholderen på bilen, er det bedst, at bilen er parkeret lige, motoren er slukket, og parkeringsbremsen er aktiveret. Sørg for, at trækkuglen er ubeskadiget, ren og ikke fedtet!

Af montering:

Lås/sikkerhedsnål trækkes ud og dreje den med en kvart omdrejning. Derpå kan håndtaget trækkes op i lodret position og cykelholderen kan tages af trækket.

Montering:

Placer cykelholderen henover trækkuglen. Tryk håndtaget nedad (ca. 35-40 kg), indtil det stopper (håndtaget forbliver stabilt i vandret position). Drej lås / sikkerhedsnål, indtil denne er fastgjort (og håndtaget kan ikke længere trækkes op).

Test nu, om cykelholderen er fastgjort stabilt nok på trækkuglen (og ikke let at vride). Hvis ikke, skal du justere på justerbolten i siden. Hvis den ikke er stram nok, tag cykelholderen af igen og skru ind i justerings skruen på hurtigkobleren. Juster ind indtil cykelholderen sidder urokkelig fast.

Caution: Vær opmærksom på at justerbolten er låst med låsemøtrikken!

Cykelholderen kan aflåses med den medfølgende hængelås. Opbevar nøglerne på et forsvarligt sted,

Justerbar bolt

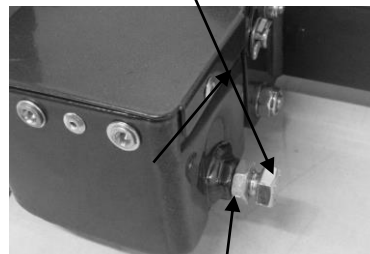

Låsemøtrik



Afstem altid om justerbolt er forsvarligt fastspændt og at sikkerhedsnålen sidder korrekt ind kørsel foretages.
Vi anbefaler at overholde gældende tilladte hastigheder.

TILTFUNKTION

For nem adgang til bilens bagagerum har vi udstyret cykelholderen med en tiltfunktion.

Først låser du op på tilt-funktionshåndtaget: Press en finger på den bageste knap (1), derpå træk håndtaget frem (2) væk fra dig.

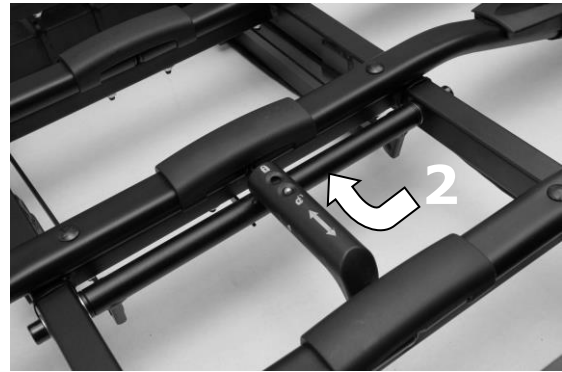

Med en hånd på cyklerne eller U-bøjlen og den anden på tilt-funktionshåndtaget, som du trækker op imod lodret for at låse funktionen op. (3). Vip forsigtigt holderen bagud.

Pas på dit hoved!

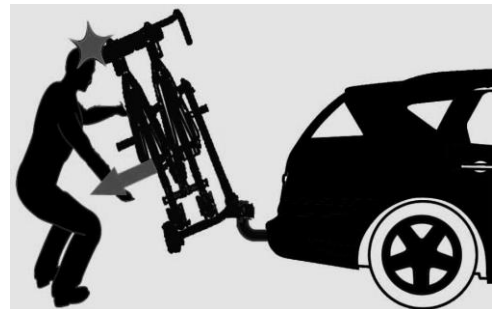

Modsat for at få cykelholderen tilbage i køreposition. Lyt efter et klik.



Sikrer dig aldrig at tilt-funktionshåndtaget er aflåst, inden kørsel påbegyndes.

BELYSNING

Denne cykelholder er udstyret med lygter. Systemet kan forbindes med bilens strømsystem med adapter. Bemærk der findes både såkaldt 7-pol stik samt 13-pol stik. Begge adaptore medfølger denne cykelholder.



Afdæk det stik som ikke anvendes med beskyttelsescover.

<p>Universal system 7 pin</p>	<p>1/L 2/54G 3/31 4/R 5/58R 6/54 7/58L</p>	<p>Indicator left Rear fog light Ground Indicator right Rear light right Stop lights Rear light left</p> <p><u>The reversing light is not working via the 7-pin plug!</u></p>	<p>yellow blue white green brown red black</p>
<p>Jaegers system 13 pin (DIN 72.570)</p>	<p>1 2 3 4 5 6 7 8 9 10 11 12 13</p>	<p>Indicator left Rear fog light Ground Indicator right Rear light right Stop lights Rear light left Reversing light <i>Not used</i> <i>Not used</i> <i>Not used</i> Ground <i>Not used</i></p>	<p>yellow blue white green brown red black grey</p>

MONTERING AF CYKLER PÅ CYKELHOLDEREN



Fjern alle løse dele på cyklen (pumper, speedometer, kurve, drikkedunke, elcykel-batterier) under transport. Disse dele kan ryste sig løse og være til fare for medtrafikanter.

Den tungeste cykel (*max 15kg*) monteres tættest på bilen og fastgøres med stelholder og hjulholdere

Stelholderne er fleksible og justerbare. Kan trækkes rundt på U-bøjlen og monteres på sadelstang eller 'herrestang' på cyklen. Vi anbefaler så høj montering som muligt for bedst stabilitet.



Cykelhjulene fastgøres med de medfølgende tekstilremme. 1 til baghjul og 2 til forhjulet. (se foto).

Cyklerne monteres modsat af hinanden således styr går fri.

Sikrer dig at anvende den ekstra sele omkring alle cykler og omkring U-bøjlen. Dette er en dobbelt sikkerhed.



Brug af sikkerhedsrem

Vi anbefaler at anvende den medfølgende sikkerhedsrem ved transport af 4 cykler. Se tegning herunder for montering og føring af rem.

Pas på om bilen har en spoiler monteret.

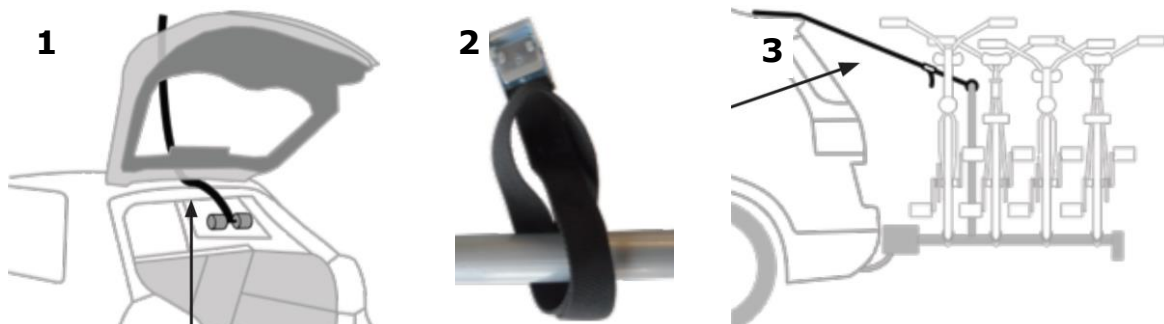

SIKKERHEDS-ANBEFALINGER

Sørg for at trækkuglen er ren og affedt.

Efter anvendelse de første par gang bør du efterjuster forankringen, som går ned over bilens trækkugle. Hold løbende øje med dette!

Check cykelholderen for eventuelle fejl inden kørsel påbegyndes. Defekte dele bør omgående udskiftes med originale dele.

Modifier under ingen omstændigheder på cykelholderen, og saml den efter vore instruktioner. Det kan være livsfarligt om ikke den samles korrekt. Vi yder ingen garanti, såfremt vejledningen ikke er fulgt, og kan ikke holdes ansvarlige for eventuelle uheld.

Altid sikrer dig at cyklerne er forsvarligt fastgjort til cykelholderen med alle medfælgende remme og stelholdere.

Sikrer dig at cykelholderens tilt-funktion er i låst-position.

Sikrer dig at anvende den ekstra sele omkring alle cykler og omkring U-bøjlen. Dette er en dobbelt sikkerhed.

Vær opmærksom på at alle løse dele på cykler er afmonteret **INDEN KØRSEL FORETAGES** (sadeltasker, pumper, skærme etc)

Check lejlighedsvis alt fungere som det skal og møtrikker og bolte er solidt spændt sammen. Efterspænd om nødvendigt.

Sikrer dig at låsen ned over bilens træk er forsvarligt aflåst.

Anbring ikke et cover omkring cyklerne under kørsel.

Kørsel med cykelholder ændrer bilens køreegenskaber radikalt. Vi anbefaler at overholde gældende hastigheder og maks 120km/t). Kør med ekstra god afstand. Undgå kraftige opbremsninger.

Husk at når du bakker med bilen at du høre n cykelholder monteret!

I tillæg vær opmærksom på eventuelle gældende landekrav for transport af gods bag på bilen.

Hvis bilen er udstyret med en automatisk åbning af bagklap, slå dette fra, når du kører med cykelholderen.

Afmonter cykelholderen før bilvaske-anlæg

Cykelholderen er ikke til "off road" anvendelse



VEDLIGEHOOLD

Opbevar altid cykelholderen ren og tørt sted efter brug. Sprøjt evt. med vandslangen for at fjerne mudder og andre beskidte ting.

Hold bilens trækkugle ren og fri for fedt.

Kontroller cykelbæreren regelmæssigt, hvis der er nogen skade. Skadede eller brugte dele skal udskiftes med det samme. Brug kun originale reservedele.

Cykelholderens møtrikker og bolte skal kontrolleres regelmæssigt, og om nødvendigt stramme dem igen.

Hvis der er en skade på cykelbærerens pulverlakering, skal dette straks behandles med maling.

Roterende og bevægelige dele skal smøres med olie regelmæssigt.

GARANTI

Dette produkt er dækket af en 2 års garanti. Vær opmærksom på, at vores garanti dækker en rimelig brug af cykelbæreren, det dækker IKKE nogen skade forårsaget af misbrug. Dette gælder også for en fejl eller fejl i cykelbæreren, der er forårsaget af dårlig eller ukorrekt installation. For at sikre garantiens gyldighed bedes du udføre vedligeholdelse i overensstemmelse med vedligeholdelsesafsnittet. Vi forbeholder os ret til at foretage et opkald og / eller reparationsafgift for ethvert arbejde, der kræves for at afhjælpe fejl, som er uden for virksomhedens kontrol, dvs. ukorrekt eller dårlig tilpasning, misbrug, utilsigtet skade mv.

INTRODUCTION

The Pro-User AMBER IV bike carrier is part of the family of bike carriers manufactured by Tradekar Benelux BV

- ✓ Hitch ball bike carrier
- ✓ Suitable for almost all types of hitch balls, bikes and wheel dimensions
- ✓ Safe and reliable, easy to tilt bike carrier for the transport of 4 bicycles
- ✓ Extremely simple and quick fitting on the tow-ball via the quick connector
- ✓ The trunk of your car is always accessible by the easy to use tilting system
- ✓ Bikes are held in wide, stable wheel holders
- ✓ Fixing of the bicycles on the frame, so no force on the pedals of your bike
- ✓ Flexible bike holding arms
- ✓ Lighting via a 7 and 13 pin (Jaeger) plug
- ✓ Including fog light and reverse driving lighting (only working via the 13-pin plug)
- ✓ The carrier can be locked to the tow ball
- ✓ European permission given by the RDW



Read the following safety- and operating instructions carefully and act accordingly before using the bike carrier.

IMPORTANT INFORMATION

Read these instructions carefully before using the product for the first time.

Do not use this product until the manual and safety regulations are read and are entirely clear.

The assembly and installation of the bike carrier can only be done according this instruction manual.

The steps that are mentioned and the safety regulations for assembly, handling and use of the bike carrier need to be followed! The slightest non conformity can lead to incorrect assembly or wrong use.

The carrier is suitable for the transport of four bikes at most. Please check the maximum permissible ball load. You can find it on the identification plate of the hitch ball of your car (for most cars this is 75kg). The total weight of the carrier with the bikes cannot exceed the maximum permissible ball load of the hitch ball.

The maximum permissible load for the carrier itself may be **60kg**.
The net weight of the carrier is **19,5kg**.

Max. permissible Ball load	Weight bike carrier	Max. load
50kg	19,5kg	30,5kg
60kg	19,5kg	40,5kg
75kg	19,5kg	55,5kg
90kg	19,5kg	Max. 60kg

Not suitable for the use on an aluminium hitch ball.

Keep these instructions in your car.

MOUNTING THE BIKE CARRIER

The bike carrier comes unassembled. Remove all parts from packaging and arrange them in a well-organized way. The instructions will clearly describe and show the parts that you need for each step and how to assemble the bike carrier.

Step 1

Parts:



Mounting:

Put the eight wheel holders on the base frame of the bike carrier with the holes right above the holes in the base frame. Then attach the wheel holders with the sixteen bolts M6x50, washers M6 and M6 nuts.

Mount the two lamp holders together. This is done by means of a small piece of iron connection that is already pre-mounted on one side. Slide the rails "together" and fix it by the supplied screw (M5x12) and washers.

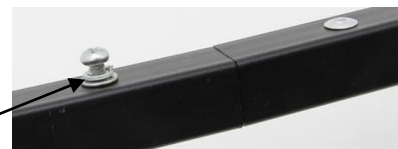

Mount the lamp holder rail at the bottom of the base frame with the two M5x35 bolts and washers.

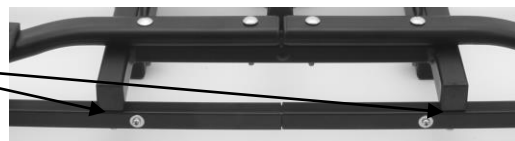

Make sure that the rear fog lamp is mounted on the left side of the bike carrier!

End result:



Step 2

Parts



Mounting:



Slide the U-frame against the outside of the U-frame holders of the base frame. Secure this U-frame with the supplied carriage bolts (M8x60), washers and plastic rotary knobs. Make sure the plastic rotary knobs are on the inside (see picture).

Please note: firmly tighten both rotary knobs so that the U-frame will come on its place well.

End result:



Step 3

Parts:



Mounting:

Loosen and remove the little screws intended for the mounting of the number plate holder from the light holder rail and fasten the number plate holder to the rail. The number plate holder has to be level with the lighting.

With the cable ties supplied with the carrier, the light cable can be fastened neatly at the bottom of the carrier. Make sure the cable will not interfere with the tilting mechanism.

Slide the twelve short, black straps through the little slots in the wheel holder, starting inside-out, going around the wheel holder and then outside-in (see picture).



Finally clip the four plastic covers over the middle of the four wheel holders.

End result:



LOCKABLE FRAMEHOLDERS

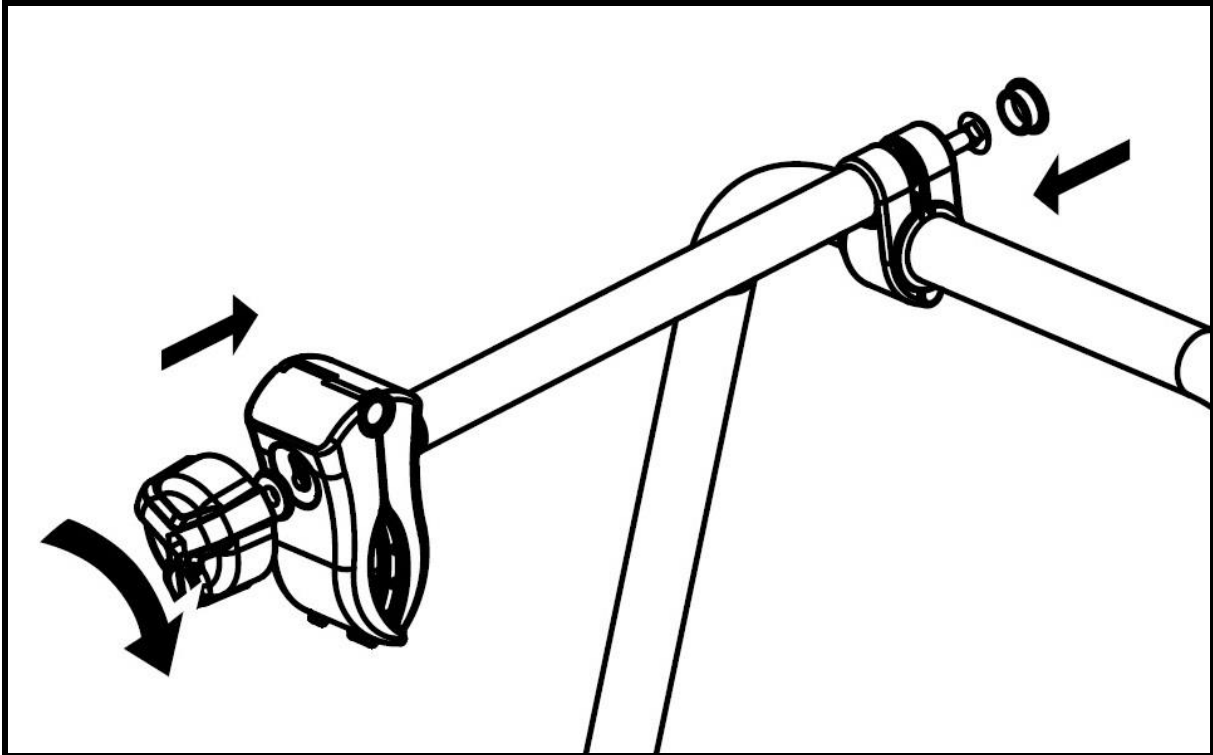
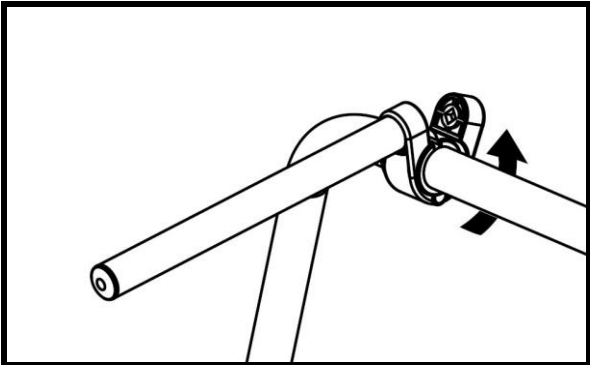
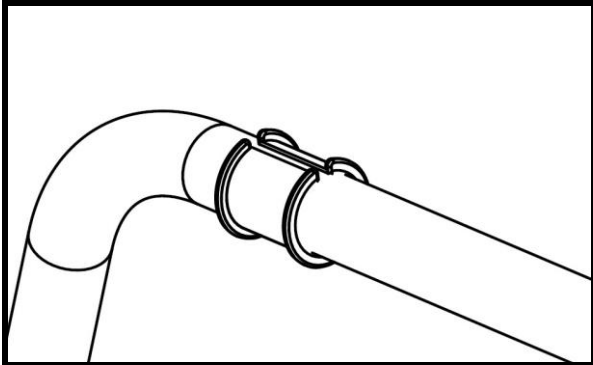
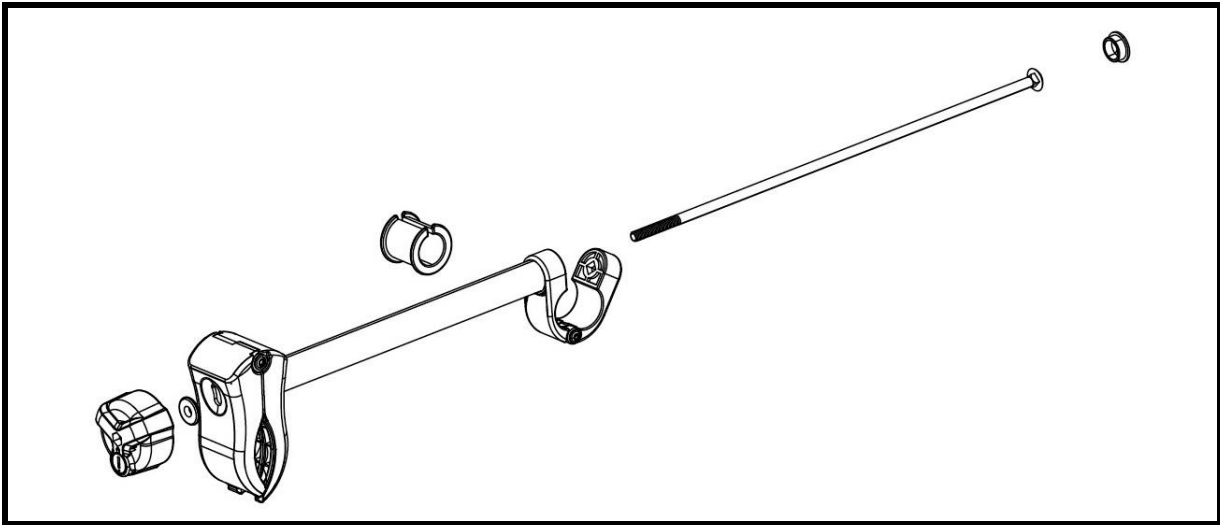

MOUNTING OF THE BIKE CARRIER ONTO THE HITCH BALL

The first step is to become familiar with the quick connector.

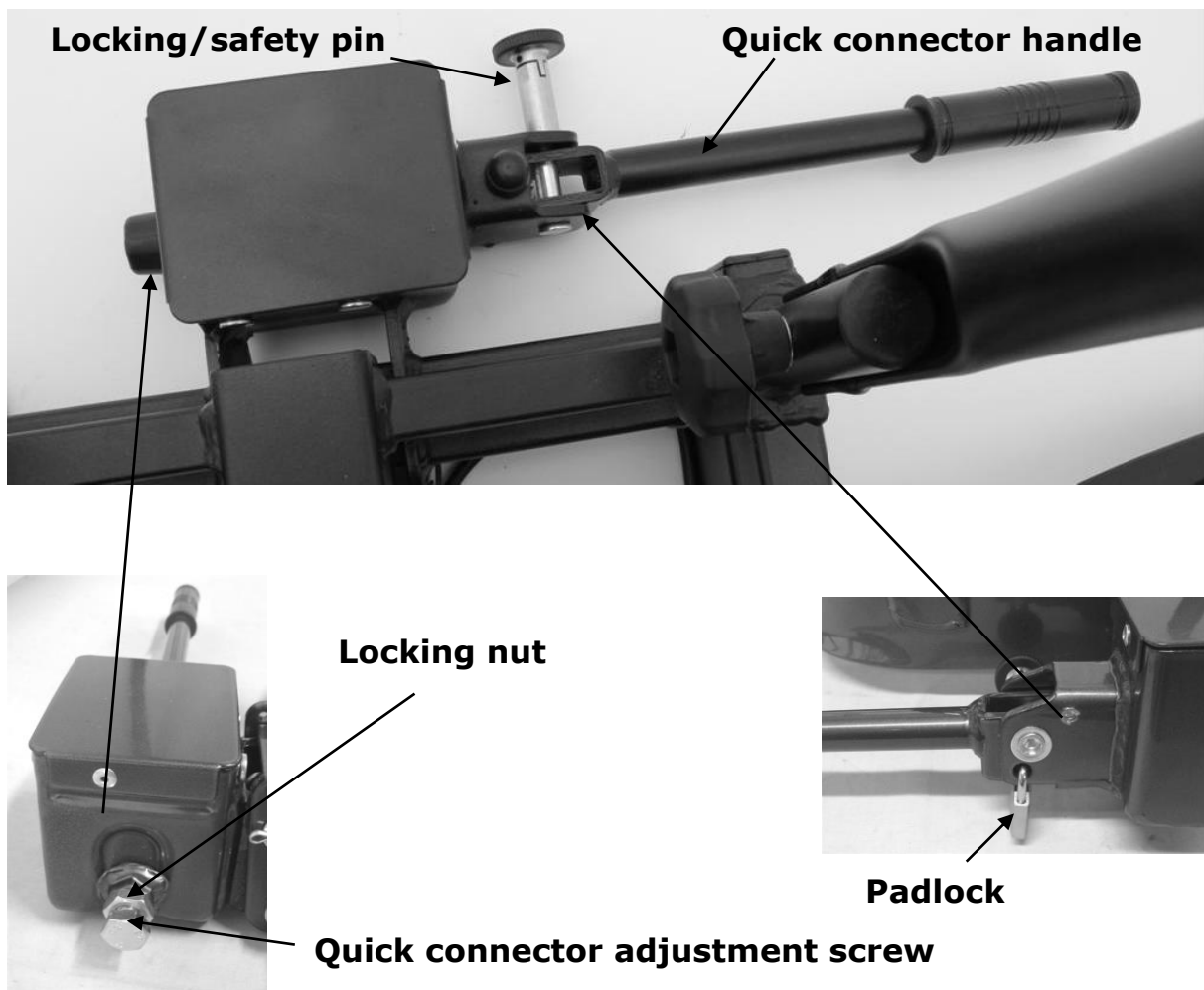

The quick connector consists of a case mounted to the bike carrier and a lever. Using the lever, you can close and open the quick connector.

When mounting the bike carrier to the car, it is best that the car is parked straight, the engine is turned off and the parking brake is activated. Make sure that the tow ball is undamaged, clean and not greasy!

Release the locking/safety pin by pulling it out and rotating it by a quarter turn. Release the quick connector by moving the handle in the vertical position.

Position the bike carrier on the tow ball from the top. Press the handle of the quick connector downwards (approx. 35-40kg) until it stops (handle will stay stable in the horizontal position). Turn the locking/safety pin until it is secured (and the handle can no longer be pulled up).

Now test if the carrier is attached steady enough on the tow ball (and not easy to twist). If not, you have to adjust the quick connector. If it is not tight enough, take the carrier off again and screw in the adjustment screw of the quick coupler

a little bit further. Loosen locking nut first, screw in adjustment screw and tighten locking nut again.

Check again if the carrier is properly secured to the tow ball (and cannot rotate easily). Repeat this until the carrier is properly secured.

Caution: Always make sure that the locking nut of the adjustment bolt is tightened again!

When the bike carrier is not easy to turn anymore, the quick connector can be locked. Lock the quick connector with the locking/safety pin and the padlock and take the key out. Keep it carefully on a safe place. The bike carrier is now also protected against theft.

Adjustment screw

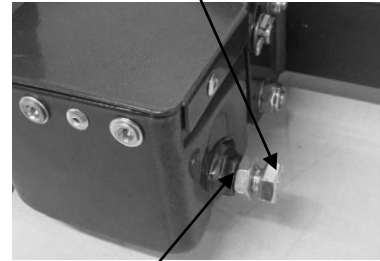

Locking nut



Always check if the quick connector is well secured with the locking/safety pin and the padlock!

TILTING MECHANISM

For easy access to your boot, even if the bikes are mounted on the carrier, you may use the tilting mechanism.

First unlock the lock of the tilting-mechanism handle: Press your finger into the rear button (1), then slide the handle (2) horizontally backwards (away from you).

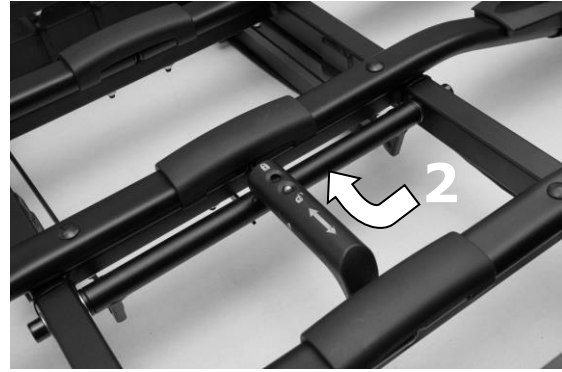

With one hand, keep a firm grip on the U-frame or bikes so that the carrier cannot fall down in an uncontrolled movement. With the other hand, pull the handle of the tilting mechanism up to unlock it (3). It is now possible to tilt the carrier.

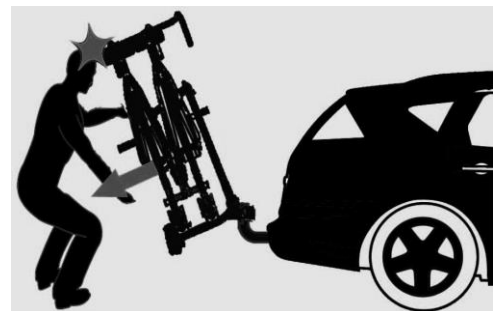

By pushing the entire carrier up, the tilting mechanism is locked again (you hear a click). Make sure to always secure the handle again by sliding this to the locking position.



The bike carrier may never be used if the tilting mechanism is not well secured.

LIGHTING

This bike carrier is equipped with a lighting system. This system can be connected to the hitch ball power socket of your car. Seeing that there are different kinds of sockets that require different kinds of plugs, this carrier comes with the usual 7-pin plug and the 13-pin plug (Jaeger). As a result, the carrier can be used with any hitch ball!



Both plugs are in one housing. Please cover the plug you don't use with the supplied cover.

<p>Universal system 7 pin</p>	<p>1/L 2/54G 3/31 4/R 5/58R 6/54 7/58L</p>	<p>Indicator left Rear fog light Ground Indicator right Rear light right Stop lights Rear light left</p> <p><u>The reversing light is not working via the 7-pin plug!</u></p>	<p>yellow blue white green brown red black</p>
<p>Jaeger system 13 pin (DIN 72.570)</p>	<p>1 2 3 4 5 6 7 8 9 10 11 12 13</p>	<p>Indicator left Rear fog light Ground Indicator right Rear light right Stop lights Rear light left Reversing light <i>Not used</i> <i>Not used</i> <i>Not used</i> Ground <i>Not used</i></p>	<p>yellow blue white green brown red black grey</p>

MOUNTING OF THE BIKES ON THE BIKE CARRIER



Remove all parts from the bikes that could easily be lost (E-bike batteries, bike pumps, speedometers, baskets, panniers, bicycle seats etc.) during transport. These parts may become loose by the increased air resistance and vibration and put other road users at risk.

The first (*and heaviest, max 20kg*) bike has to be placed in the rear wheel holder (the one which is the nearest to the car) and secured with the short frame holder on the U-tube.

The frame holders are flexible to place on the U-tube, and are also flexible to place on your bike. Try the first time which position in your situation works best (and most stable affirmative is). It is important to place the frame holder as high as possible, giving maximum stability.



Secure the wheels using the supplied short straps. One strap for the fixation of the rear wheel and two straps for the front wheel (see picture).

Place every next bike **in opposite directions** into the other wheel holders and proceed as described above for the first bike.

Now secure the bikes using the long safety belt. Run the safety belt through the bike frame and around the U frame and tighten firmly.



Use of strain relief strap

Before mounting the strain relief strap remove dust and dirt from the top of the trunk of your vehicle. Open the trunk of your vehicle. Run the free end of the strap between the trunk door and roof edge outwards (1). Leave about 20cm free between the anchor and the roof edge. Close the trunk of your vehicle gently. Make sure the strap is flat and straight between the seals. Now slowly pull the strap out until the anchor is stopped by the roof edge and the trunk of your vehicle.

Make sure that any existing roof spoiler is not damaged and that the function of strain relief strap is not affected by the roof spoiler.

Attach the part of the belt with the buckle on the U-tube of the bike carrier (2).

Connect the two parts of the strain relief strap to each other (3) and pull the strap tight.

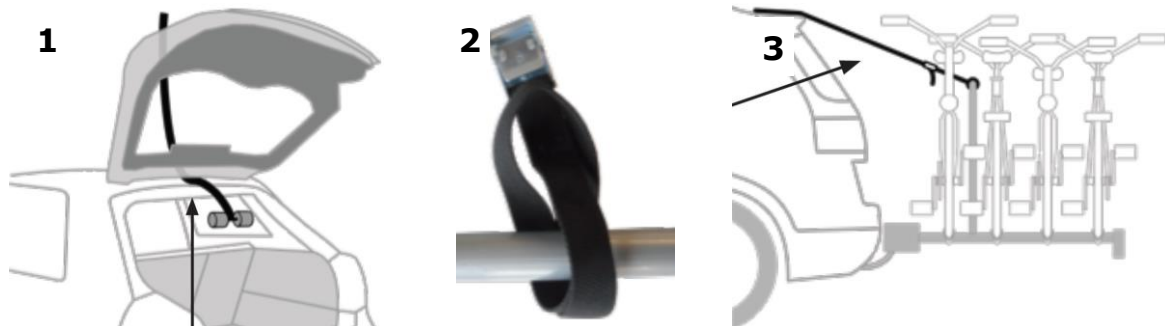

SAFETY REGULATIONS

Keep the tow ball clean and free of grease.

Each time after having mounted the carrier on the tow ball, it will "settle" during the first kilometres that you drive. Therefore, check if the carrier is still firmly secured after the first few kilometres and if necessary, tighten the locking bolt.

Check the bike carrier before use if there is any damage. Damaged or worn parts need to be replaced immediately. Only use original replacement parts.

Do not make any modifications on the bike carrier (mechanical or electronic) This can be very dangerous. Warranty claims will not be accepted and we cannot guarantee the correct functionality of the bike carrier, if you done modifications. We are not responsible for damage caused as result of incorrect assembly, installation or modification.

Check the correct operation of the lighting at regularly.

Always make sure that the bikes are firmly fixed by using the frame holders and wheel safety belts.

Always use the extra safety belt, for extra protection of your bikes. Run the safety belt trough the U-frame and the frames of the bikes, and pull this firmly.

Always use the additional strain relief strap. Connecting strap between U-tube of the bike carrier and the tailgate upper edge: To reduce the rocking of the bike carrier on uneven roads.

Make sure that no parts of the bike can get lost during driving (E-bike batteries, pump, basket, child seat, saddlebag, bicycle bag, etc.). **Always remove these before driving!**

Check regularly if all the belts, knobs and fixations are firmly secured and if necessary secure them again.

Always make sure that the tilting mechanism is locked.

Always make sure that the quick connector is closed and locked.

Do not cover the bikes with a cover while driving.

Driving with a bike carrier affects the performance of your car. Adjust your speed accordingly (**max. 120km/h**). Try to avoid sudden braking and steering movements.

Please remember when driving in reverse that the car is longer than usual!



In addition, pay attention to the regulatory requirements applicable to the transport of goods at the back of your vehicle.

When you have a vehicle with electronic parking sensors, an error message can come when the bike carrier is mounted. Switch off the parking system during the use of the bike carrier.

If the car is equipped with an automatic opening of the trunk, this must be switched off or only opened manually, if the bike carrier is mounted.

Take the bike carrier of the tow ball before using the carwash.

The bike carrier is not suitable for "off road" use.

Take the bike carrier of the tow ball if not used.

In case of defects or problems please contact your Pro-User supplier.

MAINTENANCE

Always store the bike carrier clean and dry after use. If necessary spray with the water hose to remove mud and other filthy stuff.

Keep the tow ball of the car clean and free of grease.

Keep the quick connector of the bike carrier clean and free of grease.

Check the bike carrier regular if there is any damage. Damaged or worn parts need to be replaced immediately. Use only original replacement parts.

The nuts and bolts of the bike carrier need to be checked regular, if necessary tighten them again.

If there is a damage on the powder coating of the bike carrier this needs to be treated with paint immediately.

Rotating and moving parts need to be oiled regularly.

GUARANTEE

This product is covered by a 2 year guarantee. Please note that our guarantee covers reasonable use of the bike carrier, and only applicable for parts. It does NOT cover any damage caused by misuse. This also applies to a malfunction or failure of the bike carrier that has been caused by poor or incorrect installation. To ensure the validity of the guarantee please carry out maintenance in accordance with the maintenance section. We reserve the right to make a call out and/or repair charge for any work required to be undertaken to rectify faults that are outside of the company's control i.e. incorrect or poor fitting, misuse, accidental damage, etc.

PARTS LIST

Pos nr.	Description	QTY	Remark
1	Main frame with quick connector	1	
2	U-tube	1	
3	Short frame holder	2	
4	Long frame holder	1	
5	Short frame holder "frame-frame"	1	
6	Wheel holder	8	
7	Strap	12	
8	Plastic end-cap	2	19x19
9	Lamp holder tube left	1	
10	Plastic protectioncover	2	
11	Rearlights (set)	1	
12	Plastic washer	4	
13	Washer	4	M5
14	Spring washer	4	M5
15	Self-locking nut	4	M5
16	Screw	2	
17	License plate holder	1	
18	Plastic end-cap	2	25x30
19	Washer	1	
20	Cross head bolt	2	M5x35
21	Self-locking nut	16	M6
22	Washer	16	M6
23	Carriage bolt	16	M6x50
24	Plastic cover	4	
25	Plastic knob	2	M8
26	Washer	2	M8
27	Carriage bolt	2	M8x60
28	Plastic end-cap	4	25x60

EXPLODED VIEW

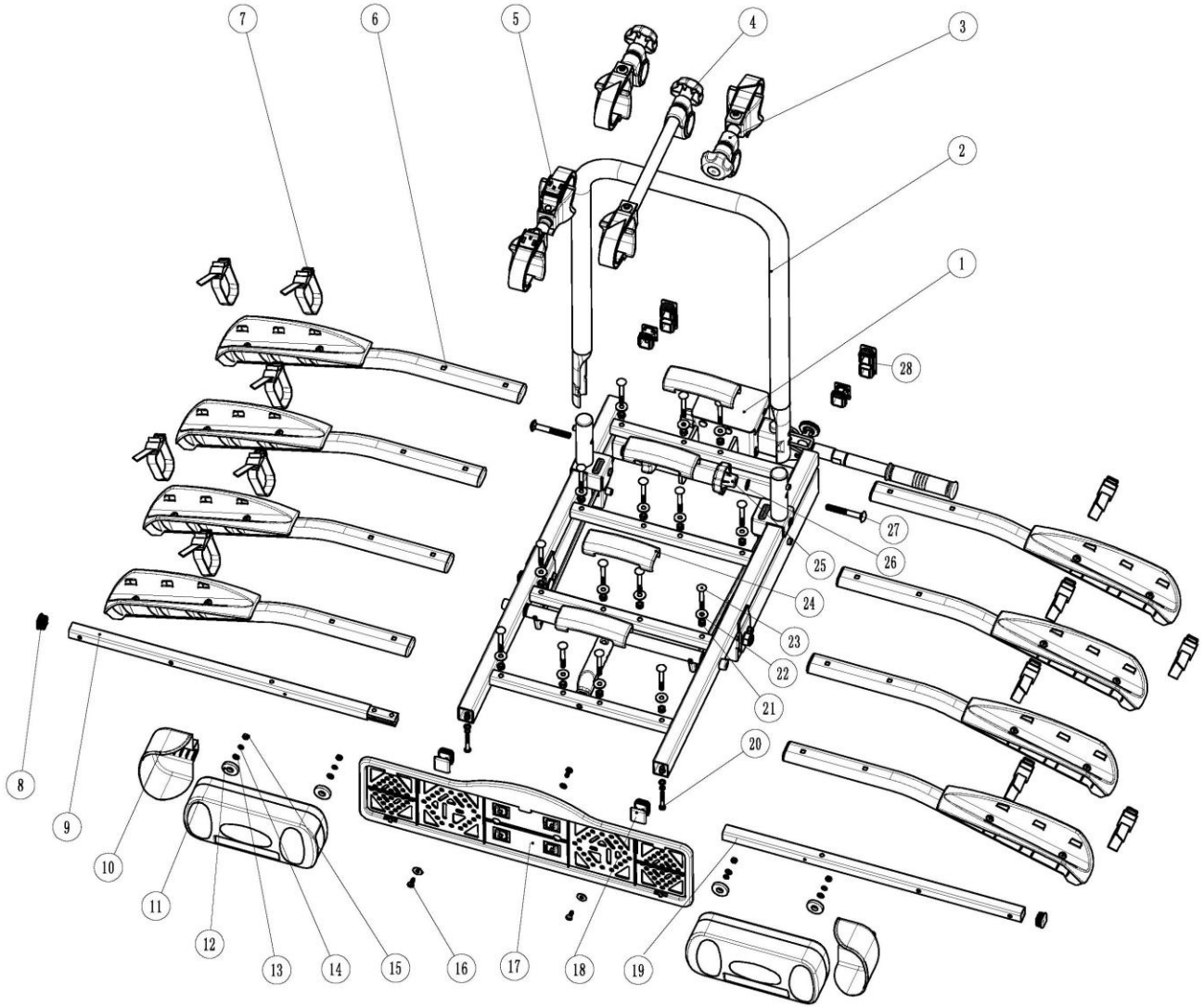

© Tradekar 91733DK/18A



Tradekar Benelux BV

Staalweg 8
4104 AT CULEMBORG
The Netherlands

+31 (0)345-470990
info@tradekar.com
www.pro-user.eu